

- PROVEN TO RUN FOR 20 YEARS WITHOUT MAINTENANCE
- PRECISION ENGINEERED, GUARANTEED TWO YEARS
- DEPENDABLE PERFORMANCE
- THREE MODELS AVAILABLE
- PARTS AND SERVICE READILY AVAILABLE ONE DAY SERVICE

FEATURES

Completely Enclosed and Sealed	Unit and case in one integral housing.
Extra Large Frictionless Bearings	Unit and case in one integral housing.
Permanent Alignment	Solid, flat base for greater contact area. Minimal possibility of misalignment due to mounting, stress and operational wear changes. Design utilizing an efficient rotary oscillating motion.
Hardened and Precision Cut Gears	Weight carrying units assembled with taper to assure rigidity.
Interchangeable Parts	Replacements easily done on site with in-house staff. Minimal loss of operating time or transportation cost. All parts available from stock.
Single V-Belt Drive	Eliminates belt slippage, requires less tension. Direct drive to weight-carrying wheel reduces power requirements.
Guaranteed for Two Years	Entire operating unit guaranteed for two years against failure due to wear when operated under recommended conditions.

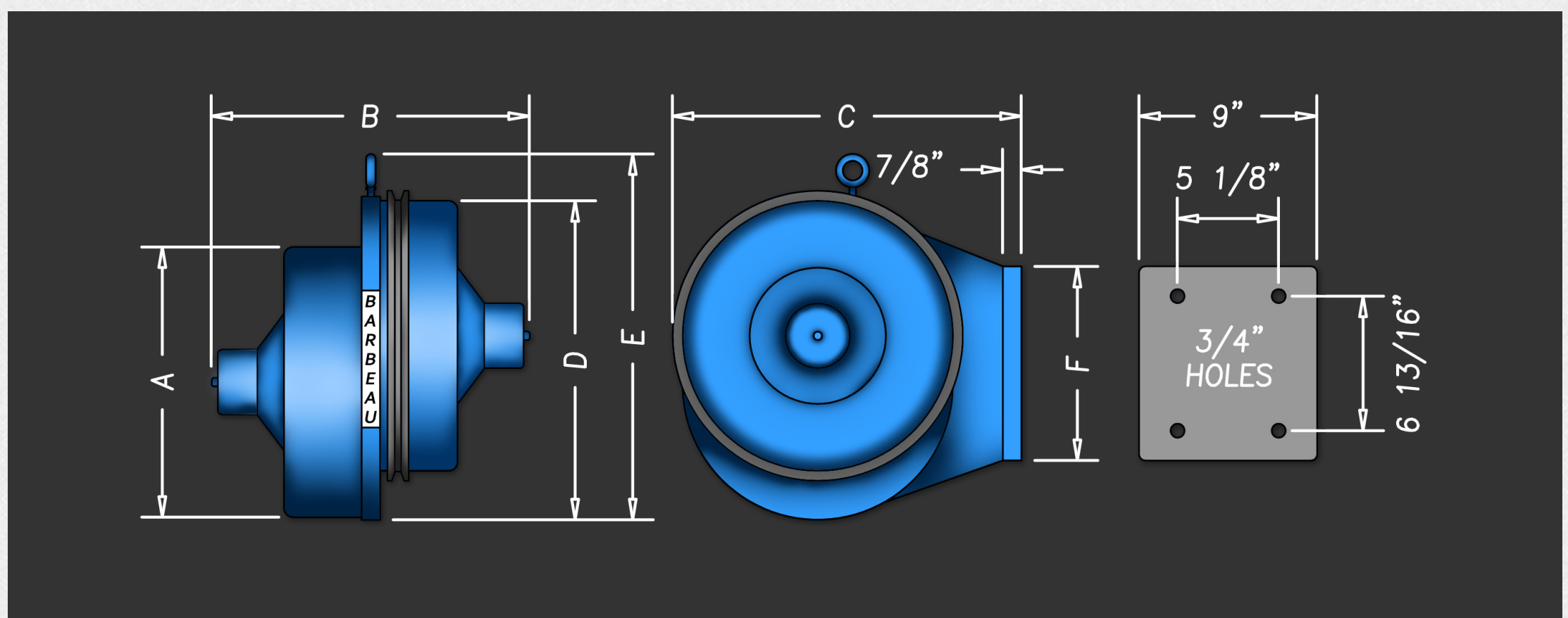

Model	A	B	C	D	E	F	Weights*	Drive**
B	11"	14 1/4"	13 1/2"	12 15/16"	15 3/16"	9"	10 - 28 lbs.	11 1/2" P.D.
A	14"	16"	17 3/4"	16 9/16"	18 3/4"	10"	28 - 38 lbs.	14 1/4" P.D.
AA	16"	6 1/4"	18 3/4"	18 9/16"	20 3/4"	10"	38 - 46 lbs.	16 1/4" P.D.

*Weights are supplied in two pound increments.

**Grooved driven wheel is 'B' belt.